

A sense of place cannot be achieved with a single building. It is the cumulative effect of each building and its relationship to surrounding buildings that creates rhythm, pattern and defines scale in the city's streetscapes.

ARTICLE IV. ARCHITECTURE

- 17.99.370 Site-sensitive building design.
- 17.99.380 Mass and scale.
- 17.99.390 Hierarchy in building design.
- 17.99.400 Prominent facades.
- 17.99.410 Windows and doors.
- 17.99.420 Siding and trim.
- 17.99.430 Roofing materials.
- 17.99.440 Design details.
- 17.99.450 Color.
- 17.99.460 Lighting.
- 17.99.470 Parking garages.
- 17.99.480 Multifamily housing standards.
- 17.99.490 Single-family and duplex housing standards.
- 17.99.500 Historic district map.
- 17.99.510 Building massing and height – Historic district.
- 17.99.520 Garage and front entry – Historic district.
- 17.99.530 Window design – Historic district.
- 17.99.540 Siding and trim – Historic district.
- 17.99.545 Railings – Historic district.
- 17.99.550 Awning design – Historic district.
- 17.99.560 Roofing materials – Historic district.
- 17.99.570 Colors – Historic district.
- 17.99.580 Preservation of historic structures.

17.99.370 Site-sensitive building design.

The following standards are applicable to all development. Their purpose is to ensure that buildings are designed to reflect the natural conditions of the site and that they include design elements that visually “anchor” the building to the site.

In order to deviate from maximum height standards, approval must be obtained through the variance process defined in Chapter 17.66 GHMC and not through the design review process.

A. Respect natural topography.

Buildings shall be designed to fit natural slopes rather than regrading the slope to fit a particular building design. Minimize cuts and fills by developing designs which complement and take advantage of natural topography. Sloped lots may require terraced parking lots and multilevel buildings designed to follow the slope.

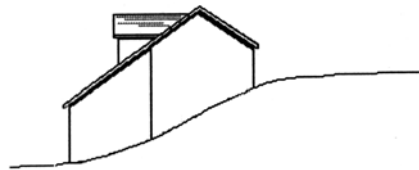

ACCEPTABLE

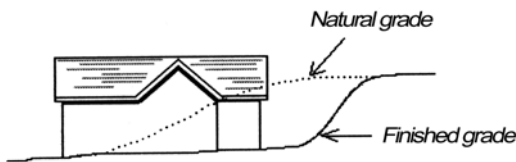

UNACCEPTABLE

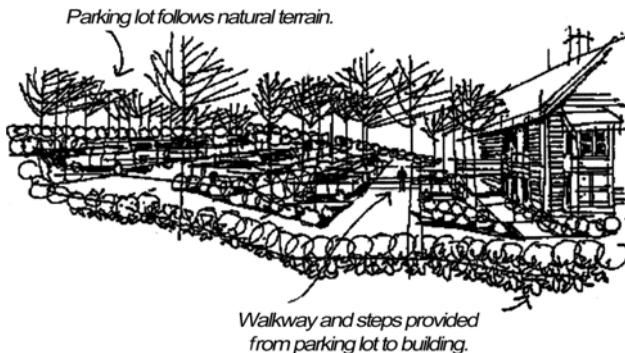

Structures should be designed to fit natural slopes. Avoid significant regrades by selecting designs which fit natural topography.

Parking lot designs should maintain natural topography as closely as possible.

B. Incorporate building design elements into landscaping areas.

Secondary design elements such as low walls, planter boxes, stairs or plaza surfaces that incorporate materials used on the building's exterior shall be incorporated into the landscape design around the building's perimeter to visually anchor and transition the building to the site.



Building designed to solidly meet the ground. Minor cantilevers are acceptable.

C. Avoid cantilevered designs.

Buildings must be designed to solidly meet the ground. Large cantilevers of building mass are prohibited. Minor cantilevers such as bay windows, and balconies are acceptable. Upper floors may not cantilever more than three feet beyond lower floor walls.

D. Determine allowable building height from any point within buildable area.

Allowable building height may be measured from any point within defined buildable areas; provided, that the point of measurement is within 50 feet of the building footprint, as follows:

1. In the height restriction area, each lot is allowed a building height of up to 16 feet; provided, that no portion of the structure exceeds 27 feet above natural and finished grade.
2. In the historic district, height limits vary. Refer to historic district standards in GHMC 17.99.510(A)(2) for residential and GHMC 17.99.510(B) for nonresidential.
3. All other areas, no portion of the structure shall exceed the maximum height of the underlying zone.

17.99.380 Mass and scale.

The following standards are applicable to all nonresidential and multifamily residential development. Their purpose is to break large structures down into smaller building modules and ensure that each module's proportions are consistent with the existing pattern of development in Gig Harbor.

A. Avoid long, low wall planes (IBE).

Prominent facades shall have no wall plane wider than two and one-half times the height of the wall plane. If a new wall plane is required to achieve compliance with this requirement, it must be offset by at least six feet.*

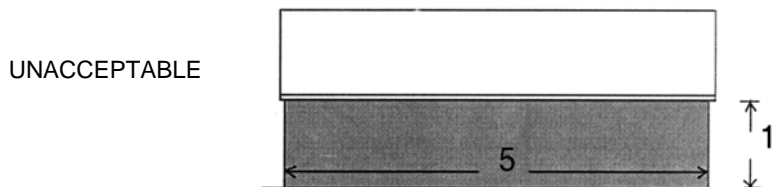
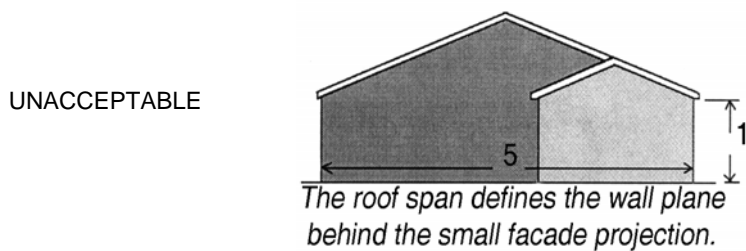
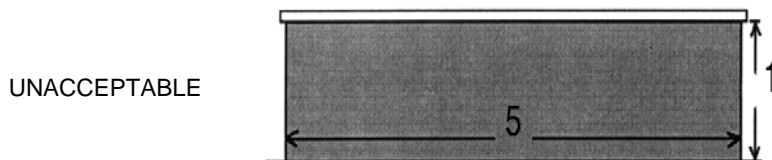
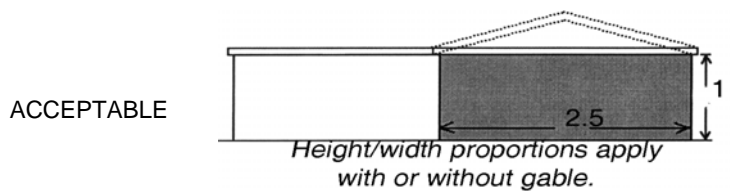

***Note: Porches, porticos and similar unenclosed projections do not affect the height/width ratio of the wall plane from which the unenclosed structure projects.**

One of the most prominent characteristics of a building's design is its scale and massing. The scale of a building determines its size in relation to its surrounding buildings, while the massing of a building gives it interest and character.

Modern building trends may emphasize large-scale designs with no thought toward massing. This imbalance between size and visual character has resulted in visually obtrusive development which is out of character with surrounding structures of a smaller scale. Large retail boxes epitomize this trend and are considered incompatible with Gig Harbor's small town characteristics.

B. Provide substantial shifts in walls and roof surfaces (IBE).

Wall and roof surfaces shall be broken down into smaller planes using substantial shifts in building footprints which result in substantial shifts in roof lines, as follows:

1. Horizontal shift

No portion of a prominent facade may exceed 80 feet in length without a shift in the building footprint measuring one-tenth of the facade length and meeting the following:

- This shift may be broken down into smaller shifts of at least six feet each.
- Horizontal shifts, when required, shall be reflected by a shift alteration in the roof design.
- To assure that footprint shifts are distributed across the building facade, shifted wall planes shall have a width proportion of between one-to-one and three-to-one the width of adjacent wall planes on the same facade.

2. Vertical shift

No single run of ridge, cornice or fascia (excluding eave overhang) shall exceed 80 feet without a five-foot transition in height. Cupolas and similar minor projections above roof lines do not meet the vertical shift requirement.

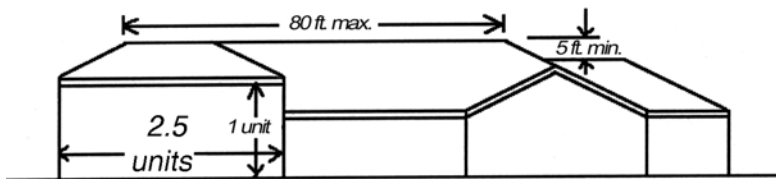

Horizontal shifts required if "A" exceeds 80 feet in length.

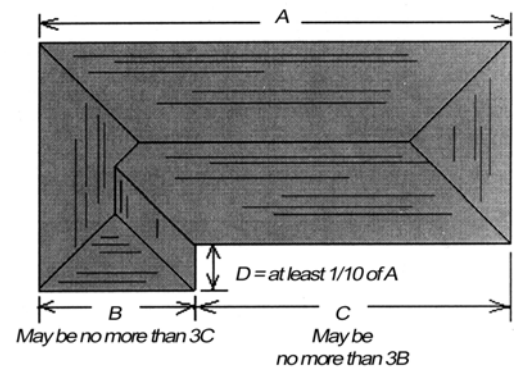
**C. Avoid a false-front look on building exterior.**

Exterior walls and roof forms shall be a true reflection of interior space. False projections of wall or roof forms are not allowed, except that parapets and gables may rise above the true roof line if they include side returns or roof planes that (1) extend back at least one and one-half times the width of the parapet or gable, or (2) extend back to a point that is not visible from any public vantage point.

D. Provide visual terminus to tops of buildings.

To avoid a truncated appearance, all structures shall have a visual "cap." This may be achieved with either a pitched or flat roof if designed according to one of the following options:

1. LOWER PITCHED ROOFS WITH EXTENDED EAVES

Except in the historic district, a lower pitched roof with a minimum 4/12 pitch is allowed provided eaves extend at least two feet beyond exterior building walls.

2. STEEP PITCH HIP, GABLE OR SALTBOX ROOF FORM

Conform to the following roof pitch requirements:

Minimum pitch: 6/12 in the historic district.
6/12 in all other areas of town.

Maximum pitch: 12/12 in all areas.

Exceptions: Steeples, bell towers and other ancillary structures.

3. FALSE PITCH ROOF WITH APPEARANCE OF TRUE HIP GABLE OR SALTBOX

Single story and multiple story buildings may have a flat roof with a false pitch if (a) the roof appears to be true hip or gable from all public vantage points, and (b) there are extending wings on each corner of the building which allow for a true hip or gable to extend out from the false hip or gable (this will avoid a mansard roof appearance). Roofs shall conform to the minimum roof pitch standards specified in subsection (D)(1) of this section.

ACCEPTABLE

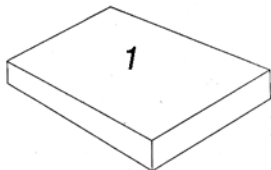
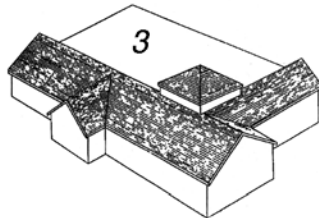

UNACCEPTABLE

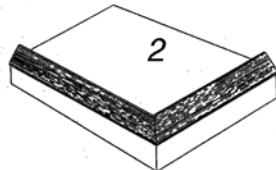

UNACCEPTABLE

1. A simple box-like structure.

2. The box structure with simulated mansard.

3. Notice how the gable extending beyond the corner of this box structure provides the appearance of a true gable from the public's vantage point.

4. FLAT ROOF WITH PROJECTING CORNICE.
 (Outside the historic district, these are allowed on multistory structures only.) Cornice dimensions must be one foot high for every 16 feet of building height and must protrude forward at least one-third the cornice height dimension. The protrusion may include the entire cornice or the cornice may be a graduated protrusion with full protrusion at the top. Cornices must be at or near the top of the wall or parapet. Pediments may extend above the cornice.



ACCEPTABLE

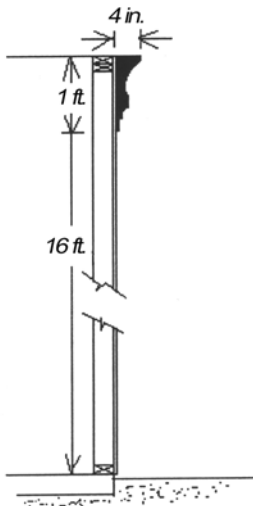

UNACCEPTABLE

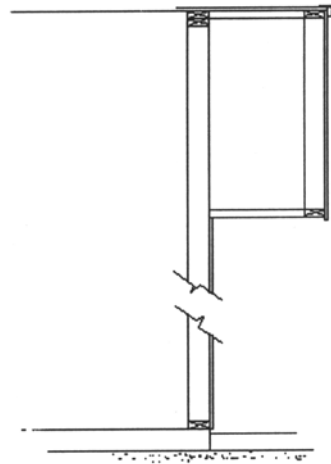

Cornices must be part of the building's trim detail. Framed projections such as overhangs or standard fascia projections do not meet the cornice requirements.

The projecting cornice provides a visual terminus to the top of this commercial building.

E. Avoid unusual or atypical roof forms on all structures.

A-frame, modified A-frame, curvilinear, domed, mansard-style roofs and unusual or atypical roof forms are prohibited. Multiple gables over a single-mass structure forming a “sawtooth” design **(IBE)** are also prohibited.

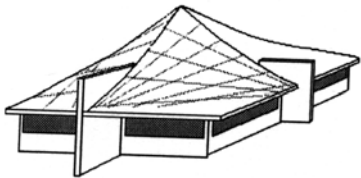
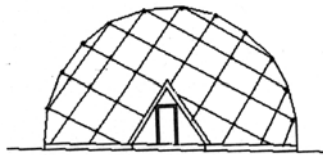
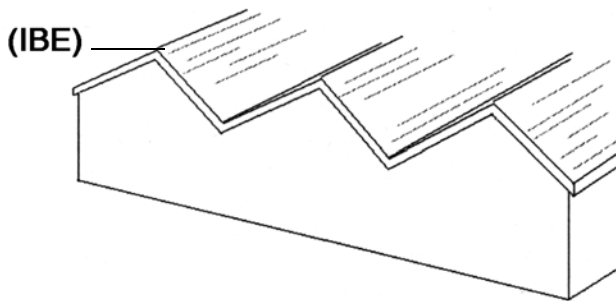
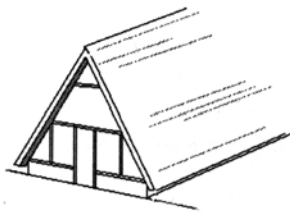
**Curvilinear****Geodesic Dome****Sawtooth****A-frame****Modified A-frame**

Examples of prohibited roof forms. Mansard roof forms are also discouraged.

(Ord. 1194 § 46, 2010; Ord. 1100 § 1, 2007).

17.99.390 Hierarchy in building design.

The following standards apply to all nonresidential sites with more than one building or with one or more multitenant buildings, and on all prominent parcels identified on the city's visually sensitive areas map (see Appendix A of this chapter).

A. Design primary structures as a focal point (IBE).

Primary structures shall be designed to serve as a visual draw to a site. Primary structures shall be designed as follows:

1. Must be prominently visible to the public.

Primary structures shall be the focal point of development and must be prominently visible to the public right-of-way giving access to the project, unless significant tree(s) warrant a less visible structure, or unless visibility is otherwise prohibited (e.g., enhancement corridors).

2. Must have the appearance of at least two levels.

To provide a more stately appearance, primary structures shall have at least two floors (minimum eight feet apart). The second floor level shall be at least one-third the area of the lower floor area. Alternatively, primary structures may be single-floor buildings with roofs having a minimum pitch of 8/12, and which contain dormer windows on every roof plane having a ridge length of 40 feet or more. One dormer window with a glazing area of at least 15 square feet shall be required for every 40 feet of ridge length (or portion thereof). Dormer windows shall be functional, providing natural light into the finished and heated area of the building.

Visual interest in the urban landscape can be achieved through a hierarchical approach to design. For example, strategically located structures, architectural elements or site amenities designed as focal points create a visual "draw" and suggest a point of activity. These also serve as a reference point for all subordinate structures. This concept is particularly applicable to large parcels with multiple structures.



Even as a stand-alone building, hierarchy is evident in this design, making it appropriate as either a multiple-tenant building or as a primary structure on a multiple-building site.

3. May have limited increased height.

Primary structures may include an area not to exceed 10 percent of the building's footprint that rises above the underlying height limit; provided, that the parcel is not located in the height restriction area defined in Chapter 17.62 GHMC. The height increase must be in building volume rather than as an extension of a parapet. This height increase shall not exceed eight feet, and shall not be applied to building heights otherwise restricted under zone transition standards in GHMC 17.99.170.

4. Must provide a prominent entrance.

Primary structures shall include a prominent entrance which faces or is clearly visible from the street. The entrance shall be defined by a projecting or recessed portico or a clearly defined doorway designed as a focal point in the facade design.

B. Integrate outdoor leisure space into primary structure design (IBE).

Primary structures shall include, either as a prominent portico or courtyard, all or portions of a common area as required in GHMC 17.99.280, which shall be visible to the public and usable to customers or clients. It shall be integrated into the building design by means of either a roof-like structure (e.g., sheathed roof or open pergola style) or perimeter wall extending from the building. Walls and roof structures shall include materials and design details that typify the primary structure.

Multiple "carbon-copy" buildings provide no visual hub and shall be avoided.



Note how these common areas have been integrated into the design of these primary structures.



C. Integrate primary structure design elements into secondary structures (IBE).

Secondary structures (all structures other than primary structures) may be much simpler in design than primary structures, but they must include design elements that visually link them to the primary structure site. Secondary structures must include siding, trim, roofing materials and colors common to the primary structure of a site. Specific combinations of materials and colors may be varied from building to building; provided, that any material or color used on secondary structures has, in some application, been used on the primary structure. For example, if the primary structure is a red brick building with gray clapboard in the gables, then the secondary structure may be a gray clapboard building with red brick accents. (Ord. 1347 § 71, 2016).



This more simple structure design would be appropriate as a secondary building in conjunction with the primary building design shown under subsection (A)(2) of this section.

17.99.400 Prominent facades.

The following standards are applicable to all nonresidential and multifamily development:

A. Provide consistent architectural interest to all prominent facades.

All building facades prominently visible from public waterways, rights-of-way or streets providing primary access to the site or from any customer or client parking or pedestrian area within a defined activity center shall meet the following facade requirement:

1. Prominent facades shall not be blank walls.
2. Prominent facades shall reflect the same design and detailing which typify the building's front including roof design, window proportion, facade variation and building materials.

B. Apply all design criteria to prominent facades (IBE).

Prominent facades, whether the front, side or rear of the building, are subject to full design review and shall comply with all design criteria stated herein.

Prominent facades include all building facades visible from waterways, public rights-of-way, or from any customer or client parking or pedestrian area within a defined activity center. Prominent facades also include facades which face the road(s) providing primary access to the building's site.

Prominent facades may not be sterile wall planes void of architectural interest. They shall be detailed with added relief, shadow lines, and visual depth.

17.99.410 Windows and doors.

The following standards apply to all nonresidential and multifamily residential development:

A. Maintain balance in the placement of windows.

To the extent possible, multiple windows on a single wall plane shall be spaced and aligned with other windows and doors on the same wall plane. Single grouped windows on a wall plane shall relate to other architectural features such as roof forms, doors, or facade projections.

ACCEPTABLE



The careful alignment of windows provides visual balance to this facade. Notice that it is not always necessary to center windows on a wall plane. Usually, however, noncentered windows look better below a hip than below a gable.

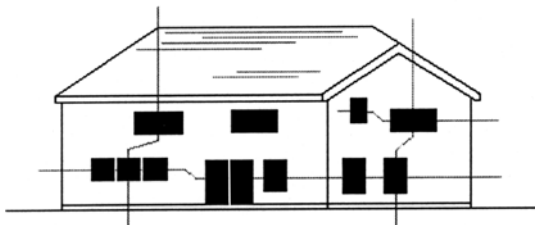

UNACCEPTABLE

The scattered and haphazard arrangement of windows on this facade result in poor balance in the overall building design.



UNACCEPTABLE

The primary purpose of windows to the interior portion of the building is to let in light and air. To the outside of a building, windows can make an architectural statement. The challenge to the architect is to make sure that both objectives are met.

Windows placed primarily to serve interior functions may appear to have been haphazardly placed on the outside of the building or may be completely lacking due to a reliance on mechanical systems for light and air. This shall be avoided.

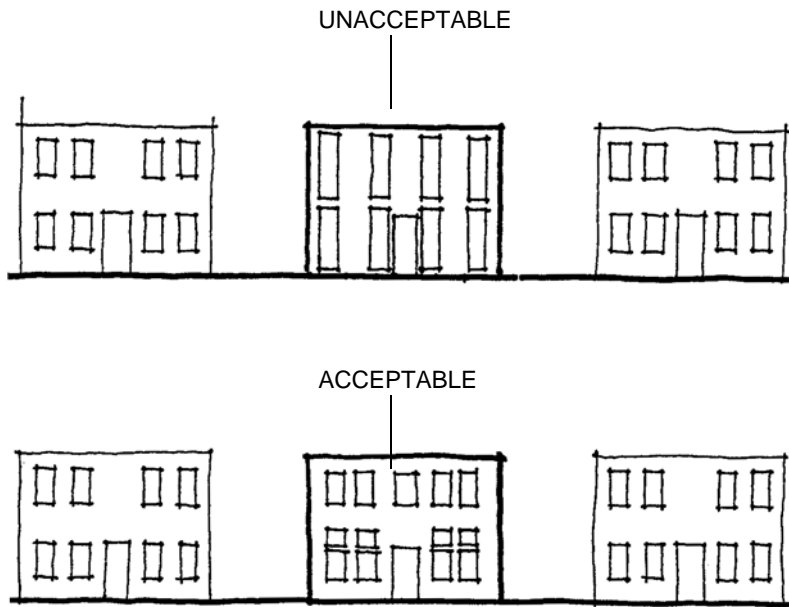

Referring to the pattern and organization of windows on existing structures can achieve a higher level of compatibility.

B. Conform to solid/void ratio requirements (IBE).

Generally, windows and doors shall constitute at least 25 to 30 percent of prominent facade wall planes. In situations where this is not practical, the masonry facade option described in GHMC 17.99.420(B) may be considered.

C. Mirrored glass is prohibited.

Windows can and should serve as a pleasing focal point in a building's design or emphasize a shift in a wall or roof plane. Windows should relate to, align with, or complement exterior design features of the building.

17.99.420 Siding and trim.

The following standards apply to all nonresidential and multifamily residential development:

A. Use siding materials that convey the same visual qualities as wood, brick, stone, stacked masonry or (in limited application) other unspecified materials (IBE).

Siding materials are limited to horizontal lap siding (of any lap design) made of wood or cement-like materials; shingles made of cedar or cement-like materials; board and batten (or panels with similarly spaced battens); brick, stone (real or cultured), nonscored, split-faced or ground-faced block (CMU). Stucco, tile, terra-cotta, concrete, spandrel glass, sheet siding (e.g., T1-11), corrugated metal panels and smooth-faced or scored concrete block may be used as accent materials, not to exceed 20 percent of any given facade. Standing seam metal siding with separately attached battens (with proportions similar to board and batten siding) may be used in gables only, or on up to 20 percent of any given facade.

B. Consider masonry facade option.

Brick, split-faced block (nonscored) or ground-faced block, if used in a manner that provides added relief, shadow lines, and dimensional interest to a facade, may serve as an alternate method of compliance to other specified design requirements, as follows:

1. ALTERNATIVE TO SOLID/VOID RATIO REQUIREMENTS

(NOTE: This option may not be used on facades facing and within 50 feet of the street or street right-of-way providing primary access to a site.) All prominent facades shall be 80 percent sided with the masonry materials stated above, which shall also include:

- a. Masonry pilasters regularly spaced every 15 to 25 feet on center (depending on the scale of the building); and
- b. Recessed "panels" in the masonry work that provide a "frame and panel" design in the masonry work between all pilasters and that comprise approximately 70 percent of the width and height of the space between pilasters. Recessed "panels" shall be recessed a minimum of four inches.

Traditional building materials such as brick, stone or wood reflect human handicraft and provide texture to building exteriors. Materials for new construction and remodeling should convey similar visual qualities.

2. ALTERNATIVE TO WALL AND ROOF SUBSTANTIAL SHIFT REQUIREMENTS

All prominent facades shall be 80 percent sided with the previously stated masonry materials, which shall also include:

- a. Masonry pilasters regularly spaced every 15 to 20 feet on center (depending on the scale of the building);
- b. Windows comprising of 25 to 30 percent of the wall plane or recessed “panels”** in the masonry work that provide a “frame and panel” design in the masonry work between all pilasters, with the recessed panel comprising approximately 70 percent of the width and height of the space between pilasters. Recessed “panels” shall be recessed a minimum of four inches;
- c. Projecting lintels and windowsills made of brick, cut stone or similar masonry material and placed above and below each main-floor window;
- d. A projecting wainscot at the base of the building made of brick, cut stone or similar masonry material per the previously stated masonry materials;
- e. A projecting string course of brick above the windows or recessed panels; and
- f. A corbelled projection in the masonry work at or near the top of the building spanning the full width of the facade, completed by a cornice made of masonry or some other material that meets standard cornice requirements.

****(NOTE: The option to use recessed panels in lieu of windows may not be used on facades facing and within 50 feet of the street or street right-of-way providing primary access to a site.)**

(Ord. 1194 § 46, 2010).

17.99.430 Roofing materials.

The following standards are applicable to all nonresidential and multifamily residential development:

A. Use roofing materials which provide texture and shadow lines.

Cedar shingles, architectural grade asphalt shingles, tile, slate, and standing-seam metal roofs are allowed. Other roofing materials are prohibited except on roofs having slopes less than 1/12.

B. Avoid bright-colored or reflective roofing materials.

Limit roofing colors to darker earth tone and forest colors. Forest greens, charcoal or medium grays and dark clay colors are allowed. Do not use clay colors that look red or purplish in sunlight.

Views of roofs from the ground and territorial roofscape views play an important role in the architecture of the city.

17.99.440 Design details.

The following standards apply to all nonresidential and multifamily residential development:

A. Avoid architectural gimmicks.

Types of gimmickry to be avoided include the following:

1. **TENANT-SPECIFIC MOTIFS** – Fanciful or unusual detailing used to promote a particular theme or to identify a specific tenant shall be avoided. Signage shall be used for this purpose.
2. **NEON OUTLINING** – Architectural features shall not be outlined in neon or tube-type lights. This includes exposed and concealed lights.
3. **BACK-LIT AWNINGS** – Awnings may not be back-lit or otherwise illuminated from behind unless the awning fabric is completely opaque so that it blacks out all light.
4. **NONFUNCTIONAL AWNINGS** – Awnings shall be limited to traditional locations over windows, walkways, and entrances or over other architectural features where weather protection is needed. Awnings must be applied to walls or posts and may not be applied to existing projections over walkways or windows.
5. **FAUX WINDOWS** – All windows must be true windows that let in light to occupied space or to large attic areas that provide at least limited standing room.
6. **FALSE FRONTS** – Building facades must be designed to reflect the mass and bulk of the structure behind the facade. Design details that create a false appearance of building mass, or that otherwise make a building appear to be something that it is not, are not permitted. This restriction is not intended to prohibit the use of decorative pediments that project above the roof line in the historic district.
7. **ARCHITECTURAL ANOMALIES** – Application of materials or details that are not integrated into the overall building design, or that do not reflect the materials or details characteristic of the overall building design, are prohibited.

Building design should be executed in a straightforward manner. Tack-on devices may not be used to mitigate poor design or to promote a particular theme. If a particular style or theme is desired, it should be reflected in the building's form and general detailing.

B. Maintain consistency in awning design.

Multiple awning designs are not permitted on a single building.

C. Avoid awnings which obscure or dominate the building design.

Awnings, canopies and marquees may not obscure architectural details of the facade and may not be the prominent design element of the building. They must appear as a secondary and complimentary element of the building design. Awnings may not extend more than 12 inches beyond the outer edges of windows or groups of windows, and they may not come any closer than 12 inches to building corners or 36 inches to eaves or cornices.

D. Orient service and delivery areas away from the streets (IBE).

Service and delivery bays and loading docks shall not be visible from public streets. Where possible, access service and delivery areas from a side street or alley. Warehouse and mini-storage doors may not directly and visibly face public streets.

E. Link dissimilar buildings with common site amenities.

Visual continuity can be achieved between dissimilar buildings by emphasizing common elements of site design (e.g., landscaping, screening, furnishings, light standards, decorative paving materials). Similar colors of structures can also provide visual continuity to the streetscapes.



This continuous awning overpowers the building design and hides the original parapet or cornice detail. Limiting the location of awnings to individual doors and windows assures that they do not overpower the building facade.



Avoid layering awnings over existing projections.

17.99.450 Color.

The following color regulations apply to nonresidential and multifamily residential development outside the historic district. The planning staff and/or the design review board can provide guidance on selecting colors that will conform to the following criteria:

A. Keep field colors subdued.

Field or base colors (the main color of exterior walls) are limited to the more subtle earthtone colors. White, soft sands, grays, sage greens, pale yellows and deep, rich clay colors are appropriate field colors.

B. Avoid bold or bright trim colors.

Trim colors (fascia, cornice, window and door trim, kick panels, etc.) may contrast to complement the field color but shall not be bright or bold. A lighter or darker shade of the field color is always an appropriate trim color, as is white. Bright or primary colors are not permitted.

C. Limit bright colors to finer architectural details.

Accent colors can generally be brighter than field or trim colors. Accent colors shall be used with restraint. Appropriate areas for accent colors are those details that might otherwise go unnoticed such as moldings or molding indentations, medallions, and shadow lines of windows and door frames. Doors are also an appropriate location for accent colors.

D. Avoid painting factory colors of stone and brick.

Stone and brick have naturally durable colors and finishes that would be lost or damaged if painted. Painting or staining of stone and brick is prohibited.

Color is an important and dominant aspect of building design.

When selecting colors, consider carefully the different materials and levels of detail that color can emphasize. The field or base color is one of the most dominating features of the building; trim colors are used on the building's secondary features, while accent colors can emphasize the finer, more characteristic elements of the building's design.

Typically, no more than three colors should be used in one building, but additional colors may be considered if they are close shades of one of the other three colors.

17.99.460 Lighting.

The following standards apply to all nonresidential and multifamily residential development:

A. Avoid back-lit panels and awnings.

Translucent panels and awnings illuminated from behind are prohibited. This shall not exclude soft light commonly and incidentally emitted from windows.

B. Keep light source hidden from public view.

Except for decorator lights which use clear 60-watt maximum incandescent bulbs (e.g., candelabra bulbs), light sources shall be concealed behind soffits, within recessed containers, behind shrubbery, etc. Sources of high-intensity light, whether behind a translucent lens or not, shall not be visible to the public.

C. Avoid bright lighting on outdoor surface of buildings (IBE).

Outdoor building lighting is limited to one 60-watt bulb (or equivalent foot-candles) on any 10 feet of facade length, except that more intense lighting is allowed at building entrances.

D. Avoid colored lighting on buildings.

Colored lighting is limited to temporary holiday lighting only.

E. Avoid light fixture designs which have a utilitarian appearance (IBE).

Designs that are strictly utilitarian in appearance are prohibited on all fixtures visible to the public, e.g., mercury vapor lights, cobra lights, etc.

UNACCEPTABLE

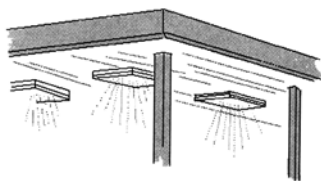
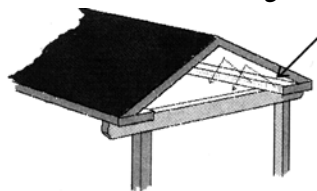
*Indirect lighting*

ACCEPTABLE

F. Use downward-directional lighting.

All lights more than seven feet above the ground shall be downward-directional lighting.

Lighting may be used to accent a building but shall not be used to denote a corporate or commercial image except on allowed signage.

Lighting may be directed to a building but should generally not emanate from a building.

The protection of neighborhoods and quality of the night sky are important goals of lighting design in the city.

High intensity light sources may not be visible to the public. Fixture designs of a utilitarian appearance shall be avoided.

Indirect lighting keeps light source hidden from the public's view. Recessed spot lighting may supplement indirect lighting where more direct lighting is desired.

17.99.470 Parking garages.

The following standards pertain to garages for four or more vehicles. They apply to all nonresidential and multifamily development.

A. Recess vehicle entries in main facade.

Garage doors and open vehicle entries must be recessed at least six feet from the front facade plane. Where possible, garage entrances should not directly face the street.

B. Screen parking garage facades.

Parking garage facades which are visible from the street shall conform to one or a combination of the following options:

1. A LANDSCAPED SCREEN – Screening may be trees and shrubs or climbing plantings on a trellis.
2. STOREFRONTS – The parking garage may be faced with storefronts or display windows.
3. SIMULATED STOREFRONT – The openings of the garage may be designed to reflect or simulate the window pattern and material choice of the primary structure on the site. The door and window fenestration requirements in GHMC 17.99.410 should be used as a guide.

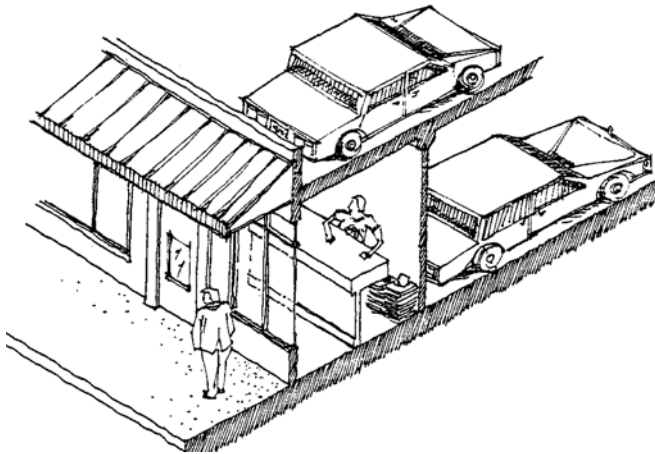

These requirements are intended to soften the visual impacts of parking garages as seen from the street face.

This parking garage is located behind an actual storefront.

C. Acquire DRB recommendation/hearing examiner approval for all parking garages over one story or which enclose 20 cars or more.

In making its determination of compliance, the DRB and hearing examiner shall consider the design criteria under subsections (B)(1) and (B)(2) of this section, and may also determine how much screening or architectural embellishment is required based upon projected lines of sight from the pedestrian's perspective.

17.99.480 Multifamily housing standards.

The following standards apply to residential structures with three or more units, and to three or more single-family units that share common walls:

A. Design units to fit slope conditions.

Housing units shall be designed to fit natural slopes rather than forcing the slope to fit a particular building design. Units shall be designed with both uphill and downhill floor plans if the site involves significant slopes.



B. Avoid parking lots oriented to the street.

Parking lots and carports shall not be located in front of street-oriented units. Driveways are allowed, as are garages, but garages shall not be the dominant architectural feature.

C. Avoid dominant garages on multifamily or high-density housing.

Keep units from looking like garages or storage units. Give visual emphasis to human enclosure as opposed to vehicular enclosure. Create focal points in the design such as front porches, larger accent windows or windows in prominent gables which project forward of the garage door and draw attention above the garage door.



There is little in this design to draw the eye away from the garage door. The design lacks a residential emphasis.

Multifamily housing is typically designed with an internal orientation leaving fences or blank walls facing the public road. To better integrate multifamily housing into the community, it should be designed to relate to the street, thereby creating a more functional interface between public and private spaces. Its design should enable as many residents as possible to relate to the street without being funneled through a common driveway or access point. Finally, its design should reflect the site's natural topography.

D. Vary design on units or groups of units.

Emphasize individuality of units with variation of massing and/or details, e.g., a combination of trim, roof-lines, porch designs, reverse designs and color variation, particularly on street-oriented units.



E. Provide consistent architectural interest to all prominent facades.

All building facades prominently visible to public rights-of-way shall meet the following facade requirements:

1. Prominent facades shall not be blank walls.
2. Prominent facades shall reflect the same design and detailing which typify the building's front including roof design, window proportion, facade variation, and building materials.
3. Prominent facades on required street-facing units may not be concealed behind high walls or privacy fences. Lower fences and walls not exceeding three feet in height are acceptable.
4. Prominent facades shall conform to all general prominent facade requirements stated in GHMC 17.99.400.

17.99.490 Single-family and duplex housing standards.

The following standards apply to all single-family and duplex residential development outside the historic district. In order to deviate from minimum setback standards or maximum height standards, approval must be obtained through the variance process defined in Chapter 17.66 GHMC and not through the design review process.

A. De-emphasize garages.

De-emphasize garages by giving visual emphasis to design elements which reflect human activity and enclosure. Choose one of the following options:

1. LOCATE GARAGE BEHIND HOUSE

A garage may be located in the defined side and rear yards provided it conforms to the following criteria:

- a. The garage is placed at least six feet behind the dwelling (a six-foot-wide breezeway (measured side-to-side) may connect the garage to the dwelling).
- b. The garage is at least three feet from the side and rear property lines or three feet from an alley access easement.
- c. The size of the garage does not exceed 24 by 24 feet.
- d. The garage is no higher than 12 feet above the highest point of natural grade along the vehicular entrance side of the garage.

2. RECESS VEHICULAR ENTRANCES

At least 70 percent of the front walls of the dwelling that enclose the living area shall project at least six feet forward of the garage doors.

3. EMPHASIZE WINDOWS AND PORCHES

Provide windows above garage doors in gables, dormers, or other wall planes that are within two feet of the garage door wall planes, along with front porches which emphasize front entries. At least one window is required for every two garage bays. Each window shall have at least 10 square feet of glazing area.

The standards of subsection A of this section represent alternative ways to de-emphasize garages located in the front of houses and include incentive to locate garages behind houses.

4. INCREASE WINDOW AREA

Garage doors may be flush with the front walls of the dwelling if the front walls include window glazing area that is at least 50 percent of the total garage door area.

Garages may project forward of the front walls of the dwelling if the front walls include window glazing area that is at least 70 percent of the total garage door area.

(Garage door windows may not be included in the glazing area calculations.)

5. PLACE GARAGE ENTRY ON SIDE OF HOUSE.

In this context, garage doors may not face the street unless it is a side street on a corner lot. If the garage projects forward of the dwelling, the garage doors must be located on the side of the garage most distant from the entry to the dwelling.

6. GARAGE DOOR PLACEMENT

Place garage doors in locations that are not visible from the street providing access to the site.

B. Emphasize front entry.

Front porches can be used to emphasize the front entry. When there is no front porch or when a front porch is not an obvious or prominent feature of the dwelling design, the front door must be oriented so that it directly faces the street.

C. Determine allowable building height from any point within setback area.

Allowable building height may be measured from any point within defined setbacks; provided, that the point of measurement is within 50 feet of the building footprint (refer to zoning code for allowed height in specific zones).

D. Avoid visually looming wall planes.

No wall plane, excluding gable areas, may exceed a height of 22 feet above any point of finished grade. Additional wall plane area may be allowed (subject to maximum building height limits) only if it is stepped back at least eight feet from the lower wall plane, or if it is in a dormer that is stepped back from the lower wall plane. Step-backs from decks, balconies or other spaces not fully enclosed do not meet this step-back requirement. This requirement applies only to prominent facades.

E. If applicable, conform to all parkway standards.

Single-family houses and duplexes on parcels having frontage on a designated parkway shall conform to all parkway standards in GHMC 17.99.110 through 17.99.140.

F. Conform to all building and outdoor lighting standards.

Single-family homes and duplexes shall comply with all outdoor lighting standards in GHMC 17.99.350.

G. Conform to all fencing standards.

Single-family and duplex development shall conform to all fencing standards defined in GHMC 17.99.340.

(Ord. 1194 § 46, 2010).

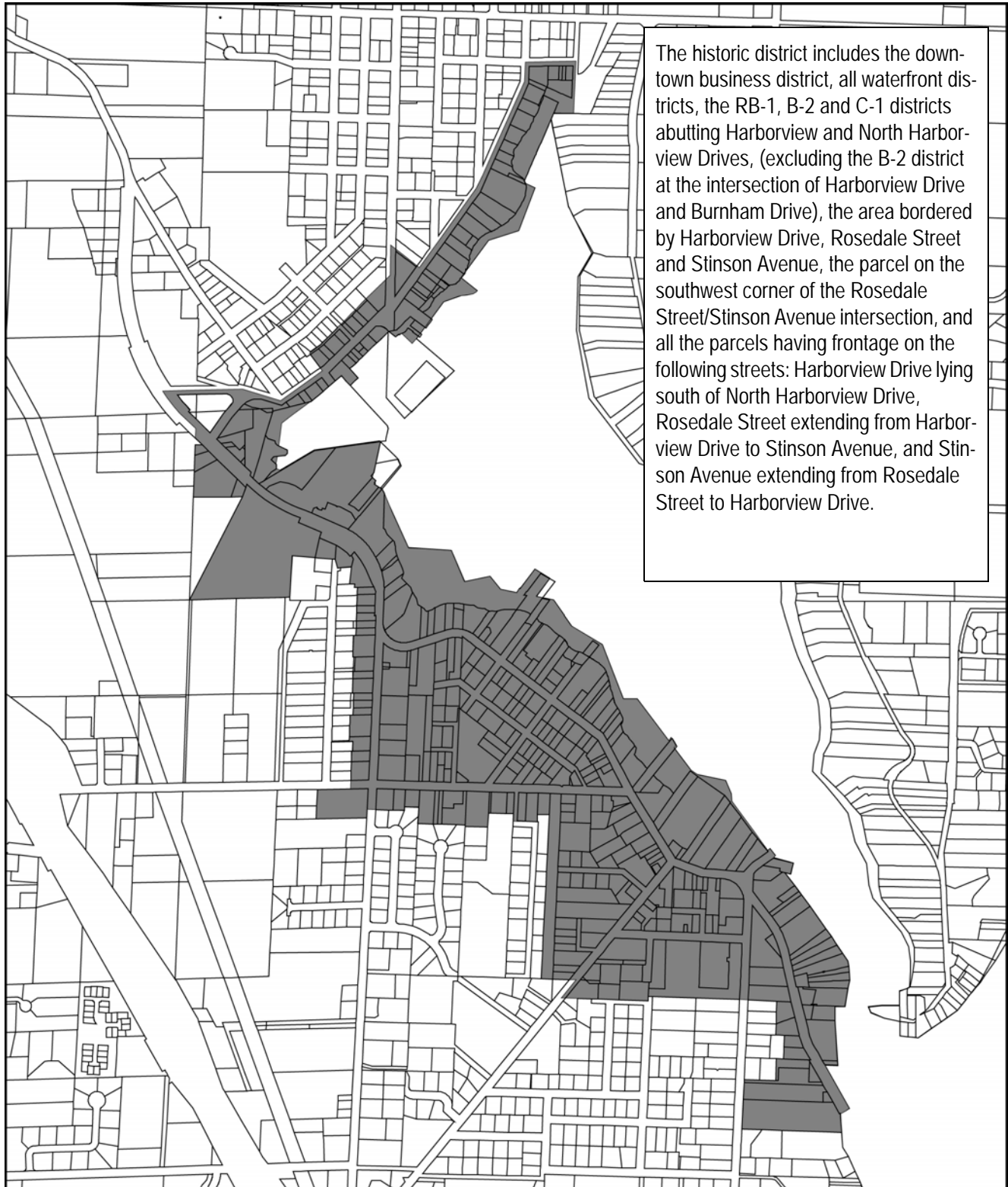

17.99.500 Historic district map.

17.99.510 Building massing and height – Historic district.

One of the most characteristic design features of Gig Harbor's historic area is the small scale and simple mass of the older homes. These structures are of modest widths, being deeper than they are wide, and include steep pitched roofs with the narrow ends of the roofs facing the street.

Historic homes are also characterized by front porches placed near the street. Garages are set back from the main structure so that the emphasis from the street is on human habitation rather than vehicular enclosure.

These elements of design have been reversed on many newer homes. Most homes built since the 1950s are characterized by horizontal dimensions with low-slung roof planes oriented to the road. The front porch has largely been replaced by front garages, with the garage often appearing larger than the house. These trends have significantly altered the visual character of the view basin and have decreased the width of view corridors between homes.

To preserve views and also to allow structures with basic historic proportions, the standards of this section shall be observed on all residential development within the historic district.

In order to deviate from minimum setback standards or maximum height standards, approval must be obtained through the variance process defined in Chapter 17.66 GHMC and not through the design review board process.



A. Incorporate characteristic roof lines and massing into residential structures.

Historic structures in Gig Harbor are characterized by similar roof lines and massing. All residential structures within the historic district must meet the following criteria:

1. MINIMUM ROOF PITCH.

Roof pitches shall be minimum 6/12 and maximum 12/12 on all portions of the roof except for (a) shed dormers, (b) porches, (c) the lower pitched roof portion on a saltbox-style structure, and (d) steeples, bell towers, and similar accentuated structures.

2. MAXIMUM HEIGHT – DB ZONE SOUTH OF ROSEDALE STREET and THE PORTION OF THE WC ZONE ABUTTING THE DB ZONE.

A building shall not exceed 27 feet above natural and finished grade as measured from the building footprint except as allowed for stepped-down buildings as follows:

On sloped sites, the elevations of buildings may be stepped down and those stepped-down sections may exceed the 27-foot maximum; provided, that the uphill and downhill facades do not exceed 27 feet above natural and finished grade as measured from the building footprint and that the amount of elevation above 27 feet does not exceed the amount of elevation below 27 feet as shown in Figure A below. Safety rails surrounding rooftop patios or gardens that are stepped back from the most forward front face of perimeter cornice are not included in the elevation provided the safety rail meets the design requirements of balustrades in GHMC 17.99.545(B) and provides a minimum of 60 percent transparency.

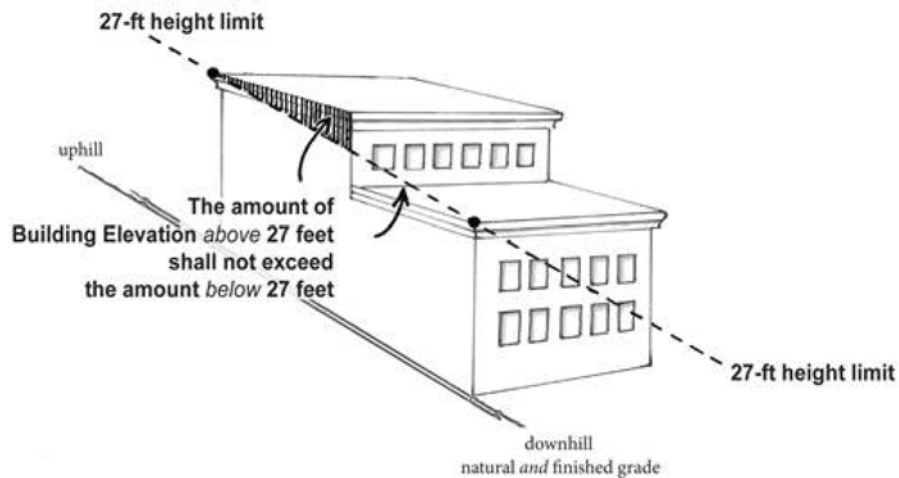

The dominating end-gable and intersecting dormer on the side typify many historic homes in the Gig Harbor basin.

FIGURE A

3. MAXIMUM HEIGHT – ALL OTHER ZONES.

Each residential lot is allowed a building height of up to 18 feet from any point within the buildable area and within 50 feet of the building's footprint; provided, that no portion of the structure exceeds 27 feet above natural and finished grade. In the Waterfront Millville (WM) zone, the point at which the 18-foot maximum is measured may be at the highest point within the lot along the street right-of-way. Additionally, one BASIC STRUCTURE measuring 25 feet wide by 40 feet deep by 27 feet high may be incorporated into the building design based upon the following criteria:

- a. The height of the basic structure shall be measured from the lowest elevation point at the setback lines. Height shall be measured from natural grade.
- b. The ridge of the basic structure shall be perpendicular to the shoreline or "point" to a significant view.
- c. No structures other than chimneys shall extend beyond the area defined by the gable or hip, i.e., no structure shall extend above the common rafter extending from the top wall plate to the ridge unless it is within the underlying 18-foot height envelope.
- d. The minimum roof pitch is 8/12. Equal pitches are used on the remaining portion of the house.
- e. A full-width front porch shall be included on the front side of the basic structure unit and windows on

the entire structure shall be true-divided light windows if a grid pattern is desired.

f. All other setback and height requirements are complied with.

The ridge line must point toward the direction of the view.

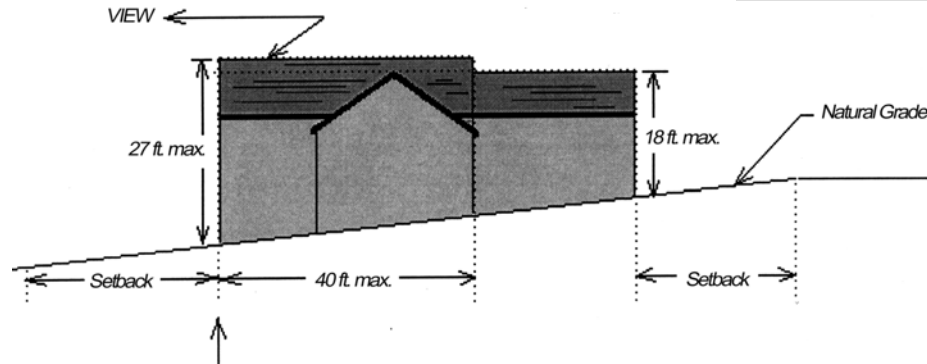

27-foot portion measured from lowest point of natural grade within setback area.

4. INTERSECTING GABLES OR DORMERS.

a. To avoid expansive roof planes, fascia boards may not exceed 35 feet in length without an intersecting gable, dormer or similar architectural element incorporated into the roof plane above the fascia board on pitched roofs.

b. The total width of all dormers, gables, and similar architectural elements shall not exceed 50 percent of the width of the roof plane on which those elements are located.

c. This requirement does not apply to BASIC STRUCTURES defined under subsection (A)(3) of this section.

The intersecting dormers and porch gable provide visual interest to this otherwise unbroken roof plane.



B. Conform to height standards for nonresidential structures.

Historic commercial structures were typically flat-roofed buildings with projecting cornices, sometimes with an extended parapet on the front. Pitched roof commercial buildings were also common. To allow similarly designed buildings, all nonresidential structures within the historic district shall conform to the following height and roof pitch standards:

1. DOWNTOWN BUILDING HEIGHTS

In the portion of the downtown business (DB) district south of Rosedale Street and the abutting portion of the waterfront commercial (WC) district, the building height limitations of this subsection (B)(1) apply as do the requirements of subsection (B)(5) of this section. In all other zones, the requirements of subsections (B)(2) through (5) of this section apply.

A building shall not exceed 27 feet above natural and finished grade as measured from the building footprint except as allowed for stepped-down buildings as follows:

On sloped sites, the elevations of buildings may be stepped down and those stepped-down sections may exceed the 27-foot maximum; provided, that the uphill and downhill facades do not exceed 27 feet above natural and finished grade as measured from the building footprint and that the amount of elevation above 27 feet does not exceed the amount of elevation below 27 feet as shown in Figure B below. Safety rails surrounding rooftop patios or gardens that are stepped back from the most forward front face of perimeter cornice are not included in the elevation, provided the safety rail meets the design requirements of balustrades in GHMC 17.99.545(B) and provides a minimum of 60 percent transparency.

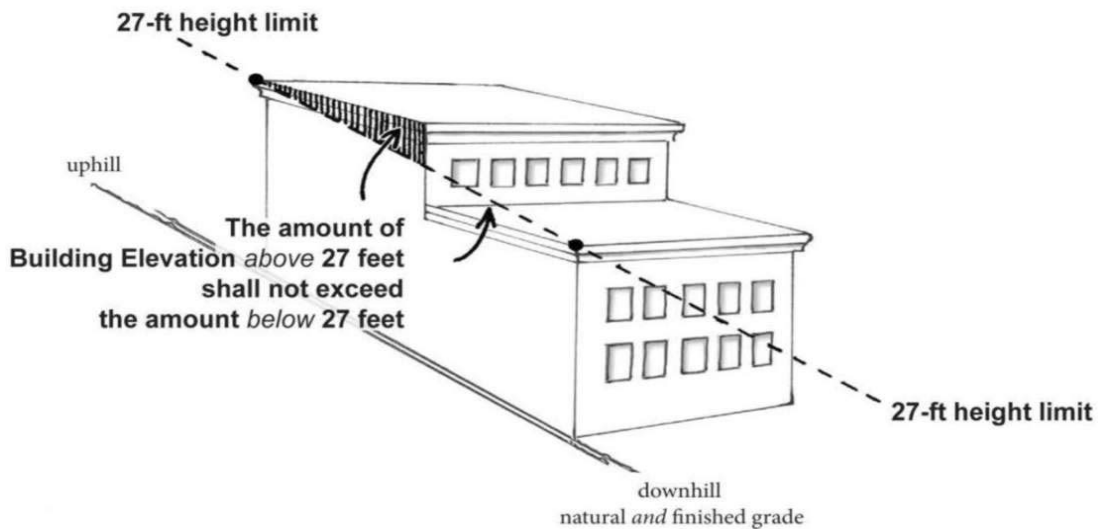
FIGURE B

2. MAXIMUM UPHILL HEIGHT

No portion of a building shall exceed 16 feet for a flat-roofed building, or 18 feet for a pitched roof building, as measured from the highest point within the buildable area and within 50 feet of the building footprint.

3. MAXIMUM DOWNHILL HEIGHT

No building shall exceed a height of 24 feet as measured from finished grade at the lowest point of the building footprint, except that additional height is allowed for roof planes, gables and dormer windows, not to exceed the uphill height limits.

4. MAXIMUM HEIGHT ABOVE GRADE

Buildings may not exceed a height of 27 feet above natural and finished grade at any given point within the building footprint.

5. PITCHED ROOFS

Pitched roofs shall have a minimum roof pitch of 6/12 and a maximum pitch of 12/12 on all portions of the roof except for (a) shed dormers, (b) porches, (c) the lower pitched roof portions on a saltbox-style structure, which may all have lesser pitched roofs, and steeples and bell towers, which may have greater pitched roofs. The ridge of a pitched roof shall run perpendicular to (pointing

toward) the view of the bay as seen from the street nearest the front setback line of the subject site, unless the ridge is within the flat roof height limits.

C. Avoid unusual or atypical roof forms on all structures.

A-frame, gambrel, curvilinear, domed and mansard-style roofs are not characteristic of Gig Harbor's historic architecture and are prohibited. Multiple gables or sheds over a single-mass structure forming a "sawtooth" design are also prohibited (see GHMC 17.99.380(E)).

D. Respect scale of adjacent structures.

To emphasize the visual pattern of the streetscape, structures shall be designed to reflect the width and height proportions of adjacent structures.

ACCEPTABLE

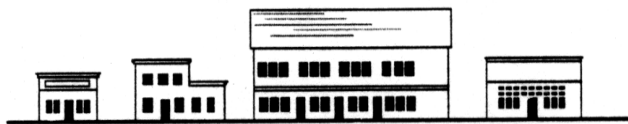

UNACCEPTABLE

Although this building is large, it includes projections which are similar in height and scale to adjacent structures.

This large single-mass building is out of scale with adjacent structures.

(Ord. 1307 § 69, 2014; Ord. 1284 § 2, 2014; Ord. 1275 § 3, 2013; Ord. 1268 § 3, 2013; Ord. 1194 § 46, 2010; Ord. 1173 § 1, 2009).

17.99.520 Garage and front entry – Historic district.

The following standards are applicable to all residential structures within the historic district:

A. De-emphasize residential garages.

De-emphasize the garage by giving visual emphasis to design elements which reflect human activity and enclosure. Choose one of the following options:

1. LOCATE GARAGE BEHIND THE HOUSE

The reduced setback provisions for garages in GHMC 17.99.320(C) may be applied.

2. RECESS VEHICULAR ENTRANCES

At least 70 percent of the front walls of the house that enclose living area shall project at least six feet forward of the garage door.

3. EMPHASIZE WINDOWS AND PORCHES

Provide windows above garage doors in gables, dormers, or other wall planes that are within two feet of the garage door wall plane, along with front porches which emphasize front entries. At least one window is required for every one or two garage bays. Each window shall have at least 10 square feet of glazing area.

4. INCREASE WINDOW AREA

Garage doors may be flush with the front walls of the house if the front walls include glazing area that is at least 50 percent of the total garage door area. Garages may project forward of the front walls of the house if the front walls include window glazing area that is at least 70 percent of the total garage door area. (Garage door windows may not be included in the glazing area calculations.)

5. PLACE GARAGE ENTRY ON SIDE OF HOUSE

In this context, garage doors may not face the street unless it is a side street on a corner lot. If the garage projects forward of the house, the garage doors must be located on the side of the garage most distant from the front entry to the house.

6. GARAGE DOOR PLACEMENT

Place garage doors in locations not visible from the street providing access to the site.

Emphasize the concept of human enclosure rather than vehicular enclosure in building designs by giving visual emphasis to windows and front entries.

B. Emphasize front entry.

Front porches can be used to emphasize the front entry. When there is no front porch or when a front porch is not an obvious or prominent feature of the house design, the front door must be oriented so that it directly faces the street.



The front porch provides an inviting appearance to this house design by giving emphasis to its entrance.

C. Respect scale of adjacent structures.

To emphasize the visual pattern of the streetscape, structures shall be designed to reflect the width and height proportions of adjacent structures.

17.99.530 Window design – Historic district.

The following standards are applicable to all development within the historic district:

A. Maintain balance in the placement of windows.

To the extent possible, multiple windows on a single wall plane shall be spaced and aligned with other windows and doors on the same wall plane. Single grouped windows on a wall plane shall relate to other architectural features such as roof forms, doors, or facade projections.

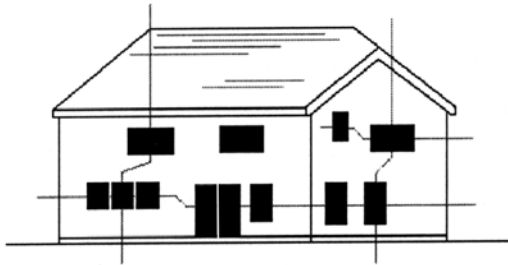

The scattered and haphazard arrangement of windows on this facade results in poor balance in the overall building design.

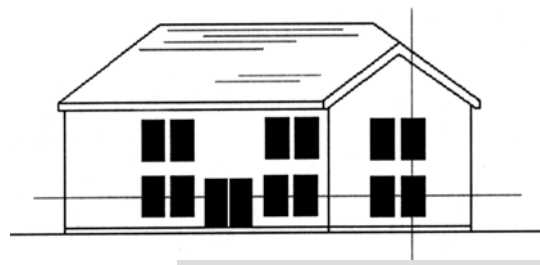

The careful alignment of windows provides visual balance to this facade. Notice that it is not always necessary to center windows on a wall plane. Usually, however, noncentered windows look better below a hip than below a gable.

B. Conform to solid/void ratio requirements.

Generally, windows and doors shall constitute 25 to 30 percent of prominent facade wall planes. In situations where this is not practical, the masonry facade option described in GHMC 17.99.420(B) may be considered.

UNACCEPTABLE

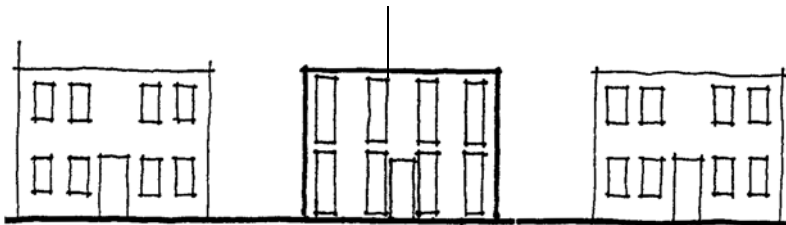

ACCEPTABLE

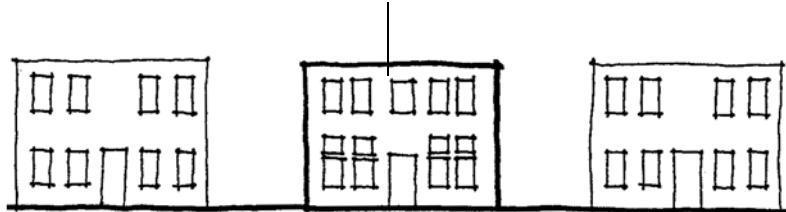

Referring to the pattern and organization of windows on existing structures can achieve a higher level of compatibility.

C. Use window muntins representative of Gig Harbor's historic structures.

Small-paned colonial windows are not indigenous to Northwest architecture and are prohibited in the historic district.

Acceptable window patterns for single- or double-hung windows include one-over-one, two-over-two, or four-over-four. Multiple-paned sashes over single-paned sashes are also appropriate. Similar grid patterns may be used on casement, slider or fixed-sash windows. On structures built prior to 1950, windows must be true divided light windows. On all other structures, artificial muntins may be used, provided they are the wider contoured grids as opposed to the narrow flat grids. Single-paned sashes without muntins (e.g., one-over-one) are always appropriate and are preferred over the use of artificial grids – particularly if window sections are divided by mullions of two inches or more.

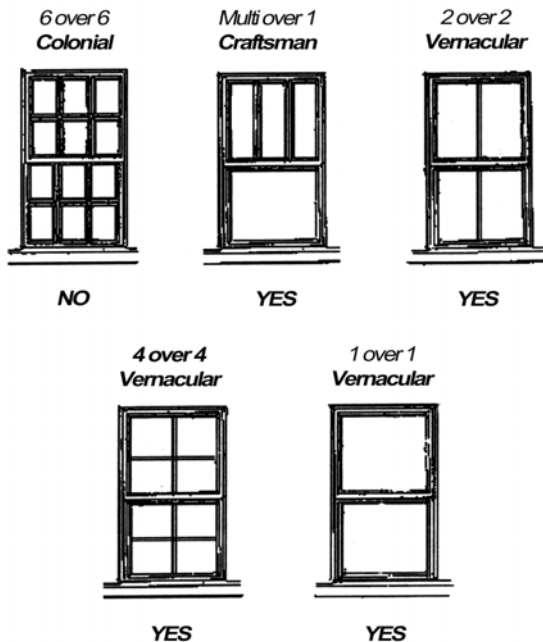

The grid patterns shown are typical of double-hung windows. Similar grid sizes and patterns are appropriate on larger fixed or casement windows.

D. Use double-hung, casement, or fixed windows.

Most structures representative of Gig Harbor's historic commercial development used fixed windows on the first level of commercial buildings and double-hung windows on second floors. Similar window placements are encouraged on new construction. If a double-hung window is not practical and an operable window is required, casement windows are acceptable, as are hopper windows combined with fixed sashes of vertical proportions. Sliding windows may only be used if egress requirements cannot be met with other acceptable window types. If slider windows are used, they must include horizontal mullions in their center to give the look of paired double-hung windows.

E. Develop and maintain vertical window pattern.

Window patterns shall be characterized by vertical proportions. Individual windows shall be no more squat than square and no more tall than three square. This requirement may be waived on portions of a building where function or building mass does not accommodate vertical windows.

F. Group vertical windows for wider openings.

On wide window areas, single windows with vertical proportions may be grouped to cover a wide space, not to exceed three windows in a single group. Multiple groupings shall be divided by a minimum 12-inch pillar.

G. Consider storefront transom windows.

Square or near square window sections may be used for ground floor storefronts if they are combined with transom windows across the top or are divided across the top to provide a transom window appearance.

H. Orient retail windows to the street.

Maintain interest at the street level in nonresidential buildings that abut the street by including retail or restaurant storefront windows on facades facing the street. All nonresidential structures and sites in the historic district must be designed to accommodate retail uses at the street level regardless of their initially intended use.

Transom-style windows above larger storefront windows are appropriate.



I. Use irregular-shaped windows sparingly.

Windows must be generally rectangular in their configuration. Circular, elliptical, octagonal, triangular, or trapezoid windows should be limited to accent windows and shall not be the prominent window form. Arched windows with vertical proportions are acceptable, but shall be limited to second level windows only. Palladian-style windows must also be used sparingly, i.e., as a single focal point in the building design.

J. Use windows with traditional frame depth and shadow lines.

Window sashes and frames shall have cross-dimensions similar to traditional wood window sashes and frames.

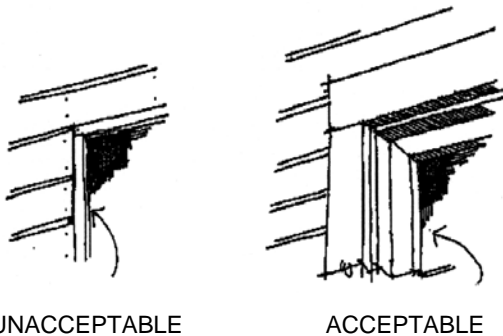

UNACCEPTABLE

ACCEPTABLE

K. Wrap windows in a traditional manner.

To provide additional detail and dimension to the window design, all windows on prominent facades shall be wrapped with minimum five-fourths-by-four-inch trim. Projecting windowsills and aprons are encouraged. This requirement does not apply to windows surrounded by masonry siding.

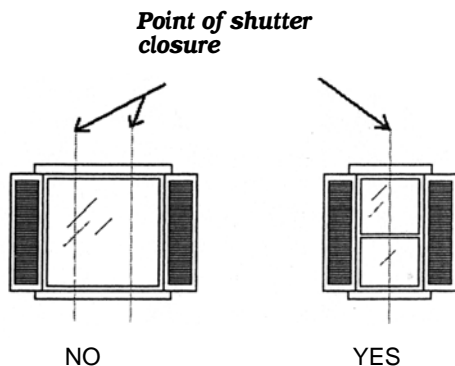

NO

YES

L. Consider width of window when selecting shutters.

Shutters must closely approximate the width of the windows to which they are attached, either in pairs or singly.

M. Reflective glass is prohibited.

Use Palladian-style window sparingly.



The window frame illustrated to the far left is too thin and provides no definition. The substantial cross section of the frame and sash shown next to it creates interesting shadow lines that will add interest to the building facade. Notice the window wrapping also.

17.99.540 Siding and trim – Historic district.

The following standards apply to all development within the historic district:

Use siding materials that convey the same visual qualities as wood, brick, stone, stacked masonry or (in limited application) other unspecified materials.

Siding materials are limited to horizontal lap siding (of any lap design) made of wood or cement-like materials; shingles made of cedar or of cement-like materials; board and batten (or panels with similarly spaced battens); brick; stone (real or cultured); nonscored, split-faced or ground-faced block (CMU); stucco on single-family homes. Stucco, tile, terra-cotta, concrete, spandrel glass, sheet siding (e.g., T1-11), corrugated metal panels and smooth-faced or scored concrete block may be used as accent materials, not to exceed 20 percent of any given facade. Standing seam metal siding with separately attached battens (with proportions similar to board and batten siding) may be used in gables only, or on up to 20 percent of any given facade.

(Ord. 1302 § 1, 2014; Ord. 1194 § 46, 2010).

Siding materials such as brick, stone or wood reflect human handicraft and provide texture to building exteriors. Materials for new construction and remodeling must convey similar visual qualities.

17.99.545 Railings – Historic district.

The following standards shall apply to all development within the historic district. All overwater piers, docks and gangways are exempt from the requirements of this section.

A. Use historically appropriate railing design for all structures either listed or eligible for listing on the city's Register of Historic Places.

1. The railing design for all structures on the city's Register of Historic Places or eligible for listing on the register based on its architecture (refer to GHMC 17.97.040(A) and (A)(2), (3), (4), (7), (10) and (11)) shall be one of the following options:

a. Railing design shall include both an upper and lower rail with turnings or nominal two-inch balusters, vertically installed. The balusters shall be connected to a top and bottom rail in a traditional manner, i.e., the balusters shall join at their top and bottom as opposed to contemporary-style connections. Face connections may occur on the back side of the rail if, from the front side, a traditional appearance is maintained.

ACCEPTABLE

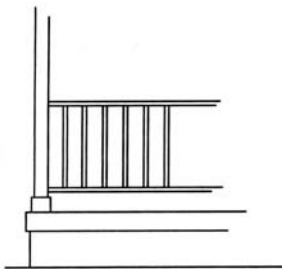

Traditional balustrade with top and bottom rail.

UNACCEPTABLE

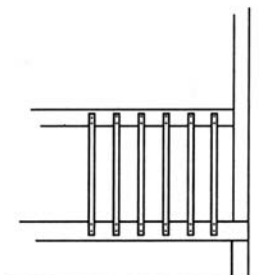

Contemporary balustrade face nailed with no bottom rail.

b. Solid panel-style railing systems provided they are capped with a traditional, reduced scale railing consisting of a top rail. Clear glass and wire mesh-style panels are prohibited.

c. In waterfront zones, horizontal cable may be used in lieu of vertical balusters; provided, that the railing design include top and bottom rails supported by spaced vertical posts with caps.

d. Rails, posts, and caps shall have the appearance and dimensions of standard lumber products.

2. In all cases, compatibility of design shall be utilized on any one level of a residential or nonresidential structure. Hand railings utilized on stairways providing ingress and egress from decks and porches shall be designed to be compatible with the railing design of the decks and porches.

The following standards shall apply to all other development within the historic district:

B. Use architecturally appropriate quality design for those structures that are either not listed or not eligible for listing on the city's Register of Historic Places.

1. The railing design for all structures not on the city's Register of Historic Places or not eligible for listing on the register shall be one of the following options:

a. Any railing design permitted by subsections subsections (A)(1)(a) through (c) of this section, except that rails, posts, and caps do not need to have the appearance and dimensions of standard lumber products.

b. Clear glass panels are permitted with or without a top and bottom rail.

c. Horizontal cable may be used in lieu of vertical balusters with or without a top and bottom rail.

2. In all cases, compatibility of design shall be utilized on any one level of a residential or nonresidential structure. Hand railings utilized on stairways providing ingress and egress from decks and porches shall be designed to be compatible with the railing design of the decks and porches. Wire mesh-style panels are prohibited.

(Ord. 1302 §§ 2, 3, 2014).

17.99.550 Awning design – Historic district.

The following standards apply to all nonresidential and multifamily development within the historic district:

A. Align bottom edge of awnings.

Maintain horizontal alignment of historic district storefronts by aligning the bottom edge of awnings, canopies or marquees with those on adjacent structures. Along sloping streets, maintain the average height of adjacent awnings.

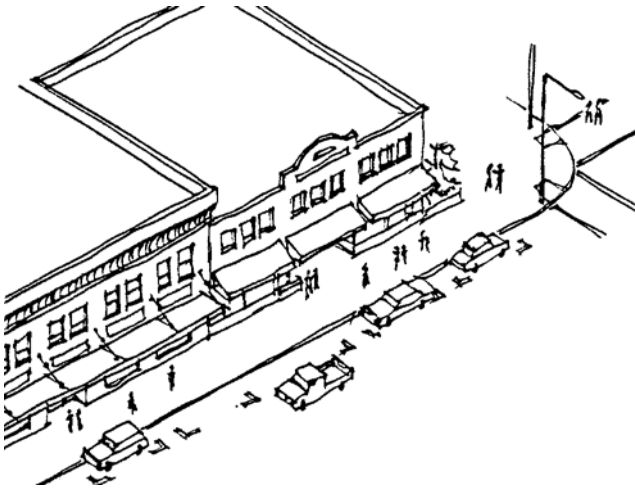

Traditional shed awnings are an appropriate “fit” for the window openings on this building. The awnings complement the facade without overpowering it.

B. Choose awning design appropriate to building style.

Awnings, canopies and marquees may not obscure architectural details of the facade. Awnings shall be either a traditional “shed” design or rounded design for arched windows. Bowed awnings, wedge-shaped awnings with wide, solid-framed valances and back-lit awnings with translucent materials do not reflect the character of the historic district and are not permitted.

UNACCEPTABLE

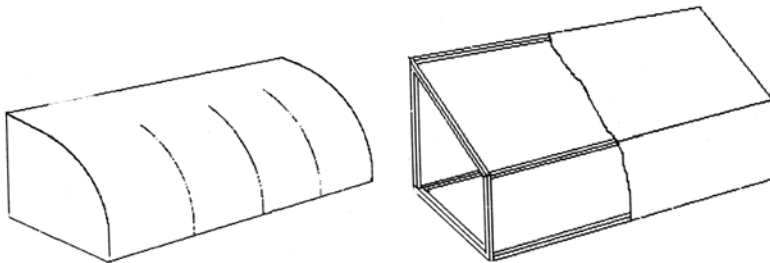

These awnings do not maintain the proportions of the more traditional shed awnings and are considered inappropriate in the historic district.

17.99.560 Roofing materials – Historic district.

The following roofing standards are applicable to all development within the historic district:

A. Use roof materials which provide texture and shadow lines.

Cedar shingles, architectural-grade asphalt shingles, tile, slate, and standing seam metal roofs are allowed. Other roofing materials are prohibited except on roofs having slopes less than 1/12.

B. Avoid bright-colored or reflective roofing materials.

Limit roofing colors to darker earth tone and forest colors. Forest greens, charcoal or medium grays and dark clay colors are allowed. Do not use clay colors that look red or purplish in sunlight.

Views of roofs from the ground and territorial roofscape views are an important element in the visual quality of the historic district.

17.99.570 Colors – Historic district.

The following color regulations apply to all structures in the historic districts. The planning staff and/or the design review board can provide guidance on selecting colors that will conform to the following criteria:

A. Keep field colors subdued.

Field or base colors (the main color of exterior walls) are limited to the more subtle earthtone colors. White, soft sands, grays, light pastels and deep, rich clay colors are appropriate field colors.

B. Avoid bold or bright trim colors.

Trim colors (fascia, cornice, window and door trim, kick panels, etc.) may contrast to complement the field color but shall not be bright or bold. A lighter or darker shade of the field color is always an appropriate trim color, as is white. When using a contrasting trim color, bright or primary colors are prohibited.

C. Limit bright colors to finer architectural details.

Accent colors can generally be brighter than field or trim colors. Accent colors should be used with restraint. Appropriate areas for accent colors are those details that might otherwise go unnoticed such as moldings or molding indentations, medallions, and shadow lines of windows and door frames. Doors are also an appropriate location for accent colors.

D. Avoid painting factory colors of stone and brick.

Stone and brick provide naturally durable colors and finishes that would be lost or damaged if painted. Painting or staining of stone and brick is prohibited.

The historic district is the only area of the city where color is regulated on single-family housing.

17.99.580 Preservation of historic structures.

The following standards apply to all structures built prior to 1950:

A. Consider design review board review of historic structure remodels.

It is strongly recommended that major remodeling proposals of historic structures be reviewed by the DRB. The DRB may be able to provide design solutions which preserve the historic integrity of a building while meeting the contemporary needs of its owner.

B. Preserve integrity of original structure's form.

Historic structures may not be "buried" behind additions and alterations. Additions to historic buildings must be stepped back from the original structure facade so that the original design remains prominent and discernible.

C. Maintain original window pattern and design.

The spacing, proportion and design of the building's original windows must be maintained and be incorporated into remodels and additions. Smaller windows may, on a limited basis, be replaced by larger windows if the muntins and mullions of the larger windows reflect the vertical proportions of historic windows. Windows divided with muntins must be true divided light windows.

D. Maintain prominent and characteristic design features of original building.

Architectural features such as front porches or bay windows which are strong or prominent features of a building's original design must be maintained. Design features which characterize a particular building period or design, such as knee braces and other craftsman design trademarks, must be maintained on the original structure.

E. Continue original building's siding and trim materials onto remodels and additions.

Building additions and remodels shall use the same or very similar types of siding and trim materials as originally found on the existing structure, except that brick or stone may be combined with wood siding.

Historic structures in the historic district of Gig Harbor make a significant and important contribution to the visual character of the harbor basin.

The standards of this section promote the preservation, renovation, restoration and adaptive reuse of Gig Harbor's historic structures and waterfront neighborhoods.